

3. Now depress barrel into stock until completely seated and move rearward until hole in the receiver and the hole in the safety block line up. Release bolt.
4. Reinsert takedown pin. Insert from the left side of receiver and press in until completely seated.
5. Replace inner magazine tube into outer magazine tube and lock.

**CARE AND CLEANING:**

As all auto-loading firearms are more sensitive to malfunctions caused by accumulations of dirt and powder fouling than *manually* operated firearms, it is important that your MARK XXII be kept clean.

**TO CLEAN BORE:**

**BE SURE RIFLE IS UNLOADED!** Pull back operating handle and leave bolt open. Insert cleaning rod from muzzle

and use bristle brush or cloth patch saturated with solvent; follow with dry patch and lightly oiled patch.

**TO CLEAN BOLT:**

Clean face of bolt with brush or cloth saturated with solvent followed by dry cloth, then slightly oiled cloth. **DO NOT USE EXCESSIVE OIL!** Wipe exterior of metal parts with lightly oiled cloth or silicone cloth. Wipe stock with silicone cloth.

**WARRANTY:**

Your Weatherby MARK XXII rifle is a precision firearm manufactured of the finest materials and has been thoroughly inspected and tested in every phase of production. Attached to your rifle is your Weatherby Warranty. Be sure it is filled in and returned to the factory.

*Weatherby*

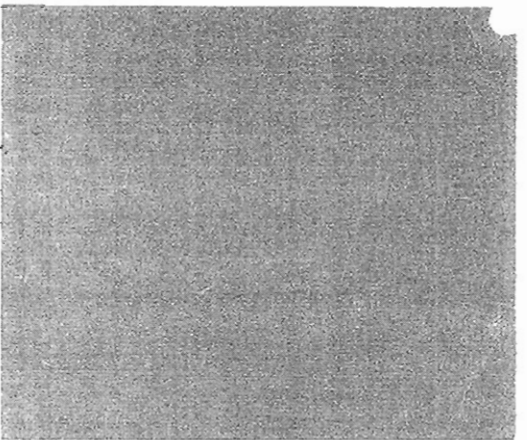

**Deluxe  
Mark XXII  
Tubular Model  
.22 semi-automatic**

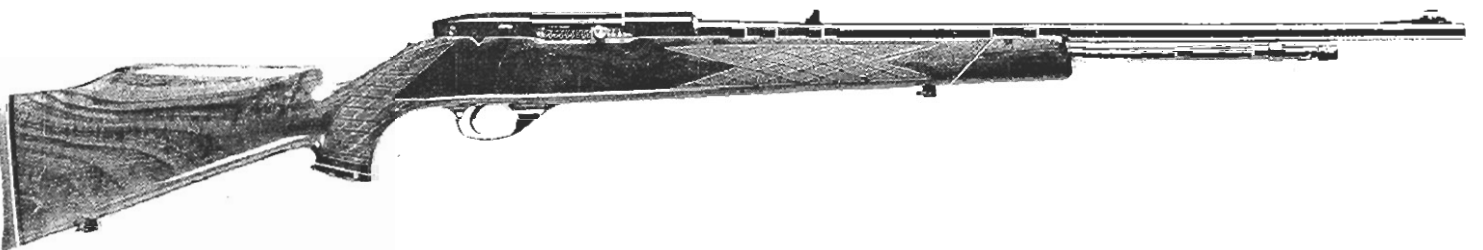
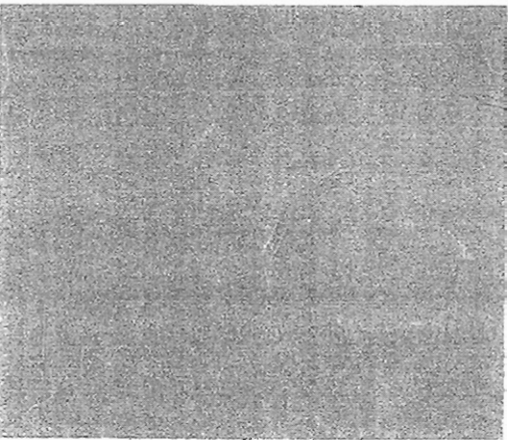

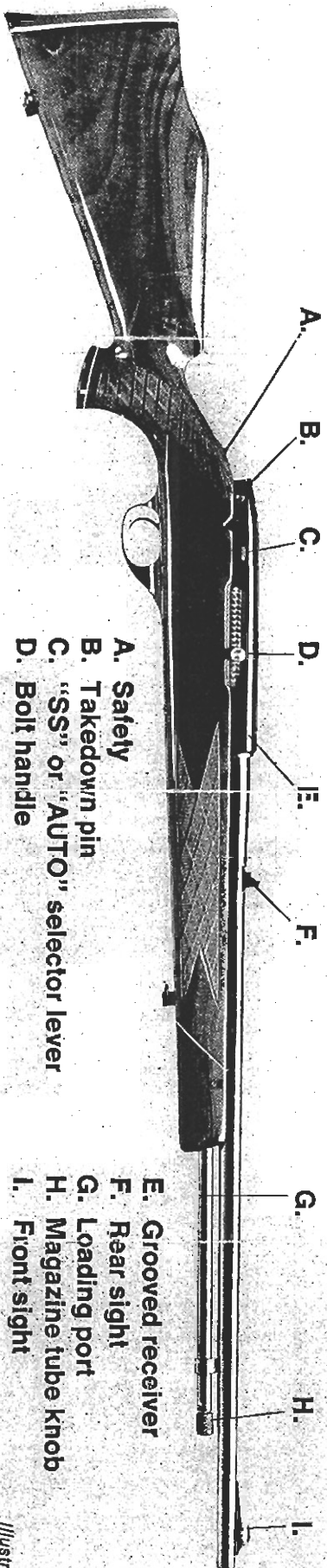

Illustration #1

**YOUR WEATHERBY MARK XXII** is the finest production sporting .22 rimfire rifle made today. We have used the same precision techniques in its manufacture that we use for the Mark V big game magnums. The finest steels and alloys, selected stock wood, and close attention to details combine to give you a .22 built to last a lifetime.

**SAFETY:**

The safety (A—see illustration #1) is located conveniently on top of the tang where it can easily be reached with the thumb. To engage safety, pull back, exposing the "S." To release safety, push forward, covering the "S."

**LOADING:**

Use only .22 long rifle ammunition, regular or high speed. **CAUTION:** Before loading, make sure the bore is free of grease or obstructions!

1. Put rifle on "SAFE."
2. Close bolt by moving selector lever (C) either to "AUTO" or "SS" (single shot) position.
3. Unlock inner magazine tube by turning knurled knob (H) at end of tube.
4. Pull inner magazine tube forward until loading port (G) in outer magazine tube is open. Load cartridges in this open port, bullet end forward towards muzzle. When magazine tube is loaded to capacity, the last round loaded will show in the open port.
5. Close magazine by sliding inner magazine tube back into magazine. Slight rotation of inner magazine tube

may be necessary to ease passage over loaded rounds.

6. When inner magazine tube is completely inserted, turn knurled knob to lock position in magazine. Note: Inner magazine tube will not lock properly if too many rounds are loaded into magazine.
7. Place selector lever in "AUTO" position.
8. Manually open and close bolt (D) one time. This will feed first round into the chamber. Rifle is now ready for use.

**UNLOADING:**

1. Move safety lever to "SAFE" position.
2. Pull inner magazine tube completely from magazine.
3. Turn rifle over and tilt muzzle slightly downward to allow loaded rounds to slide slowly from magazine. Shake rifle slightly to make sure all cartridges slide from magazine.
4. Return inner magazine tube to the magazine.

**CAUTION:** One or two cartridges may remain in the gun. It is therefore necessary to make certain both the chamber and the action are empty at this point. Place selector lever in "AUTO" position. Manually work bolt backward to extract the round in the chamber. Then work the bolt several times thereafter to make certain that the gun is empty.

**FIRING:**

The Single Shot Selector located just behind the operating handle on the right side can be set in two positions.

- E. Grooved receiver
- F. Rear sight
- G. Loading port
- H. Magazine tube knob
- I. Front sight

To fire your MARK XXII *semi-automatically* (one shot for each pull of the trigger until the magazine is empty) place the Selector on "AUTO." The fired cases will be ejected and the bolt will close automatically.

To fire your MARK XXII as a *single shot rifle*, place the Selector on "SS." After every shot the bolt will stay open. In order to release the bolt it will be necessary to push the Selector forward and this operation will close the bolt and chamber the next cartridge from the magazine. This is a valuable feature when teaching youngsters, especially when shooting on the range where safety is emphasized. The conscious effort required to close the bolt after each shot encourages deliberate thinking and actions... important in safety training.

**SIGHTS:** Your MARK XXII is grooved for a telescopic sight (E). Follow scope manufacturer's recommendations for installation.

There are three folding leaf sight settings on your MARK XXII (F): 50, 75 and 100 yards. Invariably the 50-yard setting is the one most used. Practice in range estimation will help you greatly in making the most of the other two settings. Your MARK XXII was sighted in using high-speed ammunition. As with any .22 rimfire rifle a scope is recommended.

**DISASSEMBLY:**

**BE SURE YOUR RIFLE IS UNLOADED!**  
1. Completely remove inner magazine tube from outer magazine tube.

2. Remove takedown pin (B) at rear of receiver by pushing from right to left (illustration #2).
3. With one hand, pull forward and lift upward on barrel (illustration #3). The barrel and receiver assembly will lift out of the stock.
4. The underside of the bolt and receiver recess may be cleaned as well as the hammer and selector assemblies. **NO FURTHER DISASSEMBLY IS NECESSARY OR RECOMMENDED.** Disassembly of the hammer, trigger and selector assemblies should only be performed by a competent gunsmith or at our factory.

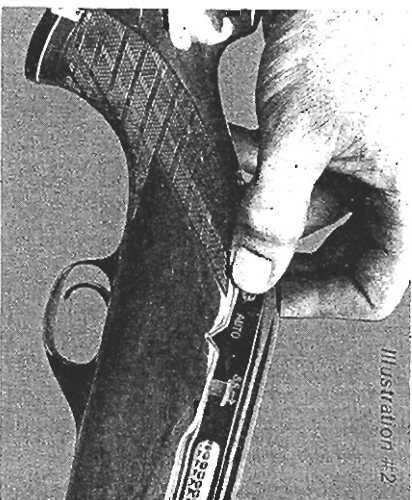
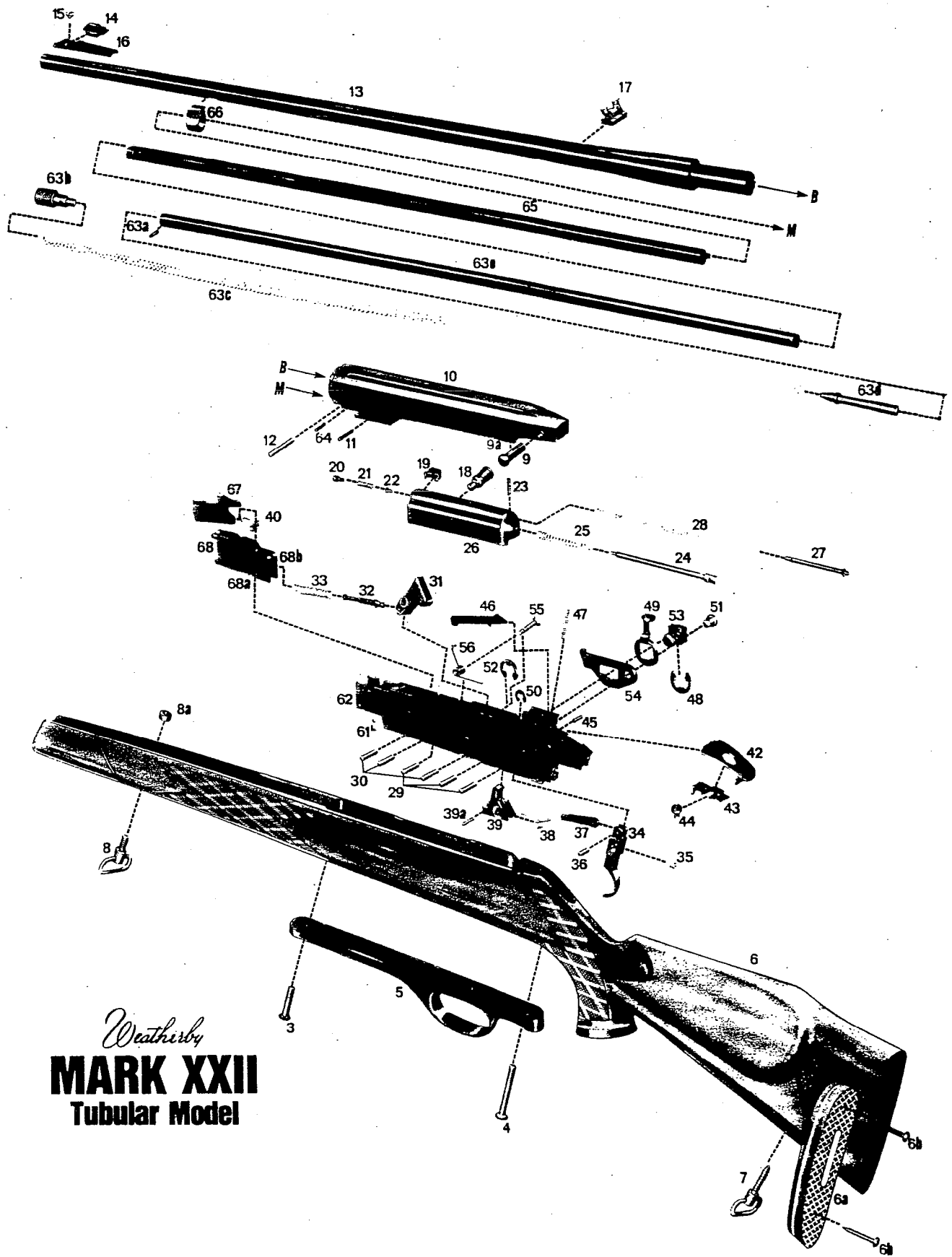

Illustration #2

**ASSEMBLY:**

1. Carefully place barrel and receiver in stock slightly forward of its normal seating position. Barrel will not yet completely seat itself into the stock.
2. With one hand, pull bolt completely rearward.



*Weatherby*  
**MARK XXII**  
 Tubular Model

## PARTS DESCRIPTION FOR MARK XXII TUBULAR MODEL

Index No.	Part No.	Part Description	Index No.	Part No.	Part Description
3	1083	Front Trigger Guard Screw	55	631	Trigger Assembly Cross Screw
4	1084	Rear Trigger Guard Screw	56	1042	Selector Spring
5	1085	Trigger Guard	61	630	Tension Screw
6	1086	Stock	62	4788	Trigger Frame Sub-Assembly
6a	1090	Butt Pad	63	4780	Inner Magazine Tube Assembly
6b	601	Butt Pad Screw	63a	1108	Magazine Plug Pin
7	4778	Rear Sling Swivel Assembly	63b	1110	Magazine Plug
8	1114	Front Sling Swivel Assembly	63c	1109	Magazine Spring
8a	1097	Front Sling Swivel Nut	63d	1107	Magazine Follower
9	1008	Takedown Pin	63e	1106	Inner Magazine Tube
9a	1009	Takedown Pin Spring	64	1103	Magazine Tube Pin
10	1028	Receiver	65	1105	Outer Magazine Tube
11	1026	Locating Pin	66	1104	Magazine Ring
12	1037	Barrel Pin	67	1087	Lifter
13	1138	Barrel	68	4771	Cartridge Guide Assembly
14	1141	Front Sight	68a	1111	Left Cartridge Guide
15	1139	Front Sight Ramp Screw	68b	1112	Right Cartridge Guide
16	1140	Front Sight Ramp	-	4786	Trigger Assembly, Complete
17	629	Rear Sight			
18	1012	Operating Handle			
19	1022	Extractor			
20	1021	Extractor Plunger			
21	1020	Extractor Spring			
22	1019	Operating Handle Plunger			
23	1016	Firing Pin Retaining Pin			
24	1018	Firing Pin			
25	1017	Firing Pin Spring			
26	1014	Bolt			
27	1011	Recoil Spring Guide			
28	1010	Recoil Spring			
29	1057	Hammer, Sear, Trigger Pins (solid)			
30	1066	Hammer Stop, Sear Stop, Lifter Spring Pins			
31	1068	Hammer			
32	1070	Hammer Spring Guide			
33	1069	Hammer Spring			
34	1056	Trigger			
35	1142	Trigger Spring			
36	1061	Disconnecter Pin			
37	1060	Disconnecter			
38	1062	Disconnecter Spring			
39	1064	Sear			
39a	1063	Disconnecter Spring Pin			
40	1088	Lifter Spring			
42	1134	Safety Tang Plate			
43	1135	Safety Slide			
44	1136	Safety Button			
45	1050	Safety Lever Pin			
46	1147	Safety Lever			
47	1052	Safety Lever Spring			
48	615	Selector Stud Retaining Ring			
49	1038	Selector Lever			
50	617	Selector Lever Pin Retaining Ring			
51	1041	Selector Lever Plate Pin			
52	616	Selector Stud Lock Ring			
53	1039	Selector Stud			
54	1040	Selector Lever Plate			